

### Lab 3.1.5 Series Circuits

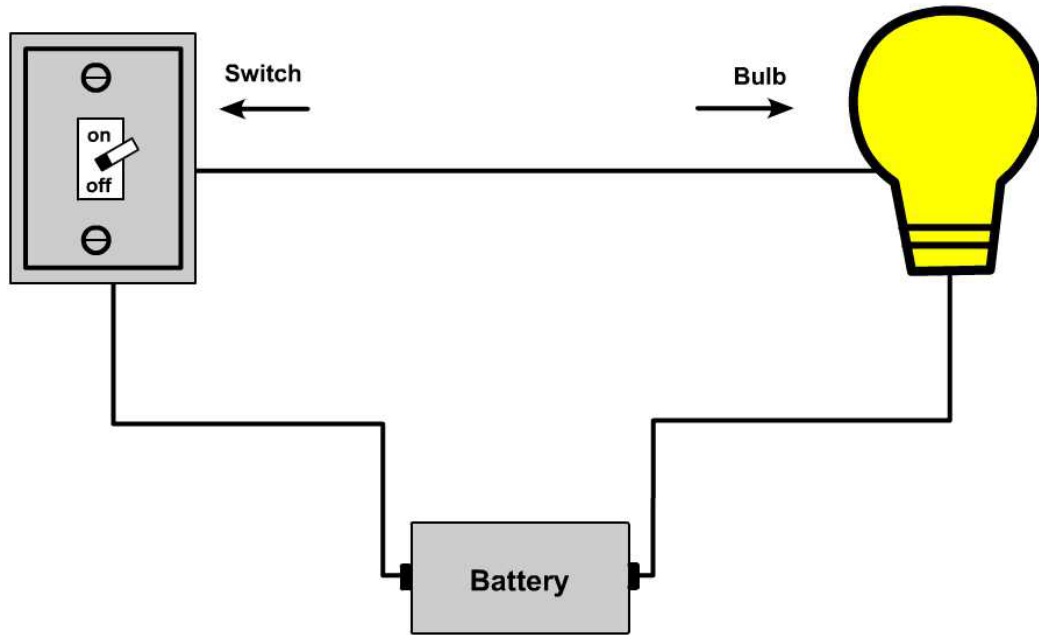

#### Objective

- Build series circuits.
- Explore the basic properties of series circuits.

#### Background

One of the basic concepts in electronics is a circuit. A Circuit is a continuous loop through which electrons flow. Throughout networking there are references to ground loop circuit, circuit versus packet switching, and virtual circuits, in addition to all the real circuits formed by networking media and networking devices. One of the fundamental electrical circuits is the series circuit. Most networking devices and networks are built from very complex circuits that are beyond the scope of the lessons included in this course. However, the process of building some series circuits will help with the terminology and concepts of networking. This lab also helps increase the overall understanding of some of the basic electrical circuit building blocks.

Prior to starting the lab, the teacher or lab assistant should have one multimeter available for each team of students and various items to create circuits. Work in teams of two. The following resources will be required:

- Fluke 110, 12B or equivalent multimeter
- Light switch
- Wire cutters or wire stripper
- Copper wire
- Two 6v light bulbs with bulb bases or LEDs with resistors
- 6v lantern battery

### Step 1 Measure the Resistances of all devices

Measure the resistances of all devices and components, except the lantern battery. All resistances should be less than one Ohm ( $\Omega$ ), except the light bulbs. All the devices except the battery should register continuity with the tone, indicating a short circuit or a conducting path.

Check the following resistances. Turn the meter off when finished or it will drain the battery.

Item to Measure the Resistance of	Set Selector and Range Scale to	Resistance Reading
Pieces of wire to connect components		
Light switch		
Light bulbs		

### Step 2

Measure the voltage of the battery with nothing attached to it, unloaded.

Item to Measure the Voltage of	Set Selector and Range Scale to	Voltage Reading
6 V Lantern battery with no load		

### Step 3 Build a series circuit

Build a series circuit one device at a time. Use one battery, one switch, one bulb, and connecting wires.

Connect the battery positive lead to the end of one wire. Connect the negative lead to the other wire. If the switch is turned on, the bulb should light.

Disconnect one device and see that the circuit is broken. Did the bulb go out?

\_\_\_\_\_

### Step 4 Measure the battery voltage

Measure the voltage across the light bulb while the circuit is running.

The switch should be turned on and the light bulb should be lit.

What was the voltage across the light bulb with the light bulb on? \_\_\_\_\_

### Step 5 Add the second bulb

Add a second bulb in series and measure the voltage across the light bulb again.

What was the voltage across the light bulb with the light bulb on? \_\_\_\_\_

## Reflection

How do series circuits apply to networking?

---

---

---